

PYROTENAX PYRO MI FIRE SURVIVAL CABLE

INSTALLATION RECOMMENDATION FOR TERMINATING PYRO MI WIRING CABLES USING SCREW ON SEALS

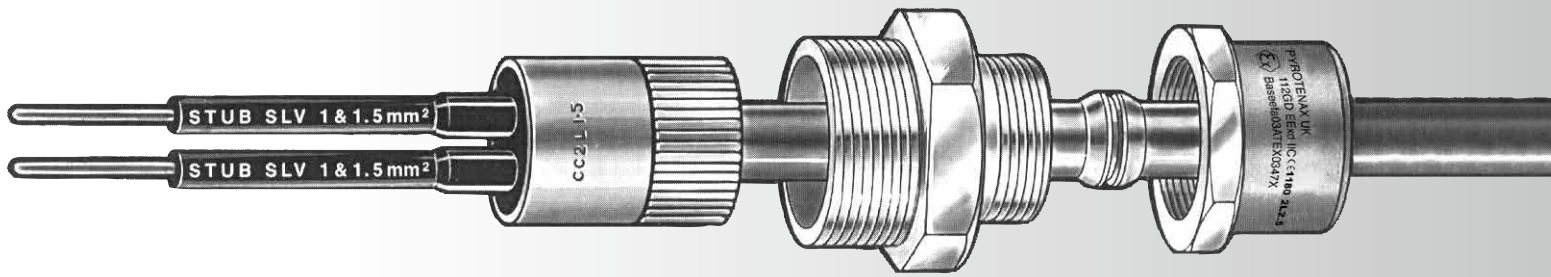

Terminations

A termination is required at each end of a length of cable and it should be fitted as soon as the cable end has been prepared i.e. cut to length and sheath removed. A complete termination consists of seal or insulator plus a gland, if required. All Pyro Mi Terminations meet the requirements of BS EN 60702-2. A variety of seals and insulators are available to suit diverse environmental conditions. Whilst they all utilise a brass screw on pot, the compound, pot closure and conductor insulating sleeves will vary.

The following table details these variations. The components for the standard, medium temperature and increased safety seals are not ordered separately because packs of seals contain all the necessary components. The glazed insulator, the fire and radiation resistant seals utilise the brass pot from the standard seal but the alternative components as necessary may be ordered separately.

Seal Type	Maximum Operating Temperature	Reference		Compound	Pot Closure	Conductor Insulation	Extension Sleeving
		Plain	Earth Tail				
Standard	105°C	RPS	RPSL	Grey Plastic Ref. RMX	Black Plastic Stub Cap	PVC Sleeving Ref. RZP	Not required
					Black Plastic Disc	Headed PVC Sleeving Ref. RZD	PVC Sleeving Ref. RZE
Glazed Insulator	250°C	-	Not Available	Glazing Flux Ref. RMG	Not Required	PTFE Sleeving Ref. RZPT	Not Required
Fire & Radiation Resistant	105°C (950°C - 3hr)	-	-	Grey Plastic Ref. RMX	Black Plastic Stub Cap	Silicone Elastomer/Glass Sleeving Ref. RZPS	Not Required
Increased Safety [†]	85°C	RPA	RPAL	Grey Plastic Ref. RMX	Pink Plastic Disc	Headed PVC Sleeving Ref. RZD*	PVC Sleeving Ref. RZE

[†] Not available for 12 and 19 core cables.

* Headed PTFE Sleeving Ref: RZHT used for certain sizes of earth tail seal.

This publication contains instructions for the fitting of 105°C, Fire and Radiation Resistant Seals. The sheath stripping and pot fitting methods described are also applicable to the 250°C Insulator and Increased Safety Seals.

Further detailed instructions necessary for completing the 250°C Insulator are contained in Installation Recommendation CDE-0924 Rev. 0-1/06 while the Increased Safety Seal is covered in Installation Recommendation CDE-0928 Rev. 0-1/06 (instructions are also included in the pack).

Typical Pyro Mi Brass Seal Assemblies

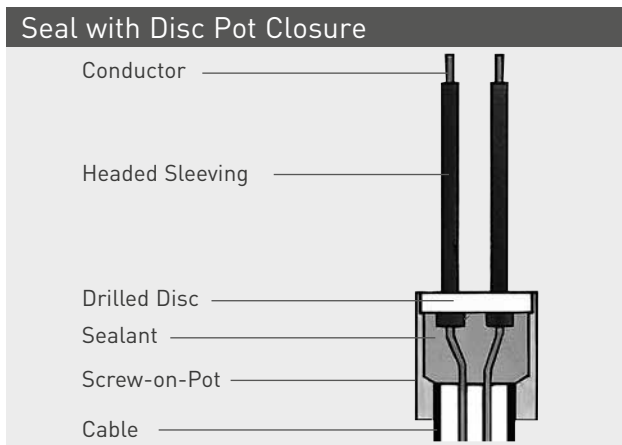
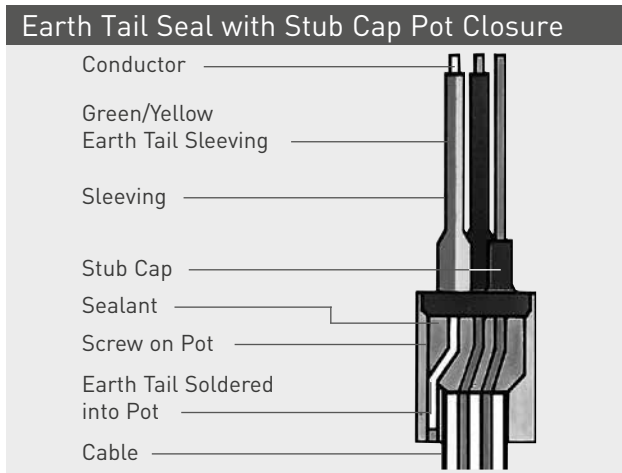
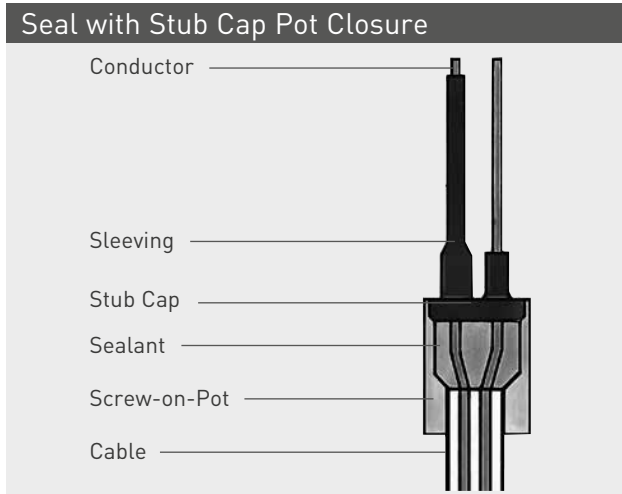

Earth Tail seals are available incorporating a 150mm length of protective conductor identified by green/yellow striped sleeving. The dimensions of screw-on pots are shown below.

SEAL POT SIZE	DIA	LENGTH
20	14.8mm	16.7mm
25	21.2mm	25.5mm
32	26.8mm	31.8mm
40	33.2mm	34.2mm

Compound

Additional 100g packs of grey plastic compound are available, sufficient to fill 32 x 20mm, 10 x 25mm, 5 x 32mm or 2 x 40mm sealing pots.

Glands

Externally Threaded Gland - Ref. RGM

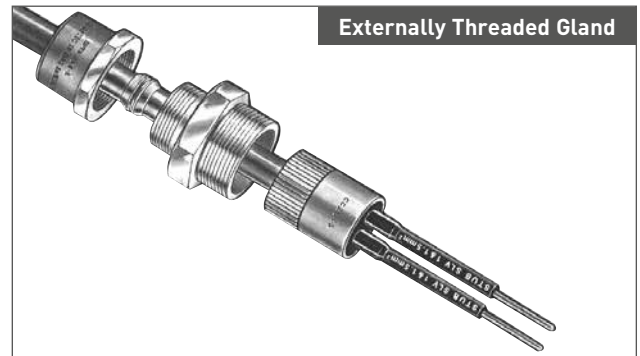

RGM Glands are ATEX certified for use in hazardous areas. This means that the RGM gland can be used with flameproof apparatus sub-groups IIA, IIB, IIC. It is also suitable for all other "types of protection" and all general applications.

Entry thread	'X'	20mm	25mm	32mm	40mm
Gland body hexagon	A/F	22mm	27mm	36mm	46mm
A' max	A/C	25.4mm	31.2mm	41.6mm	53.1mm
Entry thread Length 'B'		11mm	11mm	11mm	11mm
Assembled Length 'C' (approx.)		21mm	24mm	26mm	28mm

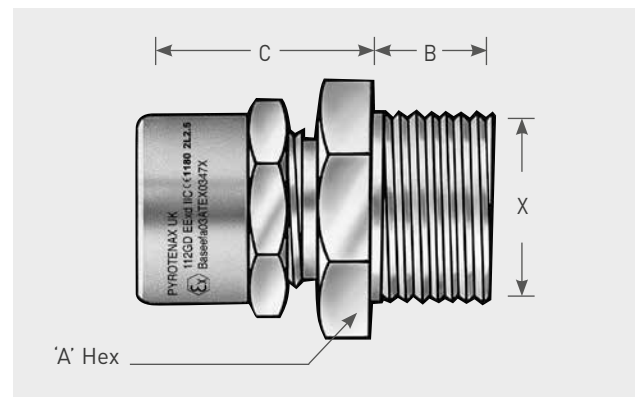

Brass locknuts can be supplied for securing externally threaded glands into unthreaded entries. Locknut dimensions are as follows.

Thread size	20mm	25mm	32mm	40mm
Hexagon across flats	24mm	30mm	36mm	46mm
Hexagon across corners	27.7mm	34.6mm	41.6mm	53.1mm

Stripping The Cable Sheath

First cut the cable to length with a hacksaw. Next mark off the required length of tail plus the measurement as indicated in the table below for different size seals. Then, using one of the 3 methods described later, strip back the sheath to this mark thus exposing the conductors.

Seal size	20	25	32	40
Length of tail plus	11mm	17mm	20mm	25mm

Cable with Outer Covering

After cutting cable end square, offer up the shroud to the cable end, in reverse, to determine the amount to be cut off to ensure a tight fit over the covering. Cut the shroud accordingly. Mark the covering to the required tail length, plus an additional amount as indicated in the table below for different gland sizes. Remove the covering to the mark with a knife, taking care not to nick the metal sheath. Then mark and strip the copper sheath as above.

Gland size	20	25	32	40
Length of tail plus	70mm	70mm	80mm	90mm

Method 1 - Using Rotary Stripping Tools

Three rotary stripping tools are available

- A) The Large Pyro Stripper Reference ZSU.
- B) The Small Pyro Stripper Reference ZSUS.
- C) The Joistripper Reference ZSJ.

The Large Pyro Stripper

The large Pyro Stripper will accommodate all sizes of cable by adjustment of the knurled screw and locknut. The small 'v' of the reversible block will accommodate cables up to 8.5mm diameter (see Fig. 1a). For cable above this size the larger 'v' must be used (see Fig. 1b). Positioning of the appropriate 'v' can be affected by slackening the retaining screw, reversing the block (ensuring that the chamfered edge is on opposite side to cutting wheel) and then retightening the retaining screw.

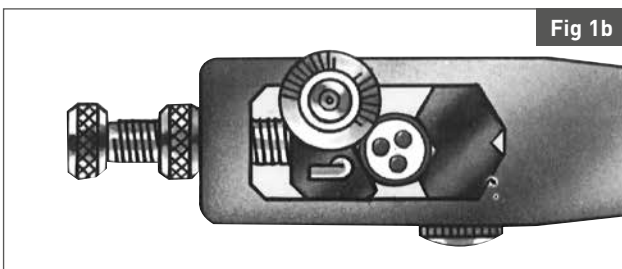
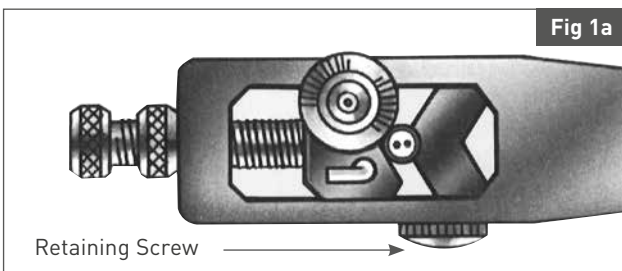

The Small Pyro Stripper

The Small Pyro Stripper is suitable for use on cables up to 9.0mm diameter. This tool has a fixed 'v' block and is adjusted by means of the knurled screw. A spare cutting blade is provided in the rear body of the tool secured by a small screw.

The Joistripper

The Joistripper is the sheath removal tool specially recommended for the most popular 2, 3 and 4 core light duty cables.

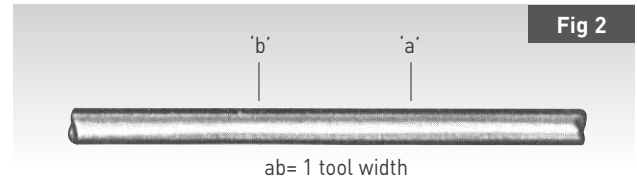

Having previously marked the sheath at the point where stripping is to stop (point 'a' in Fig. 2), add a second pencil mark one tool width further along the sheath (point 'b' in Fig. 2) to indicate the position for location of the pliers. When using tool reference ZSU or ZSUS insert the cable into the tool as far as the face of the cutting wheel (Fig. 3). Tighten knurled screw until the tool can just support its own weight in a horizontal position.

Slightly release screw until tool can just fall under its own weight and finger tighten locknut. (No locknut is fitted to Small Stripper).

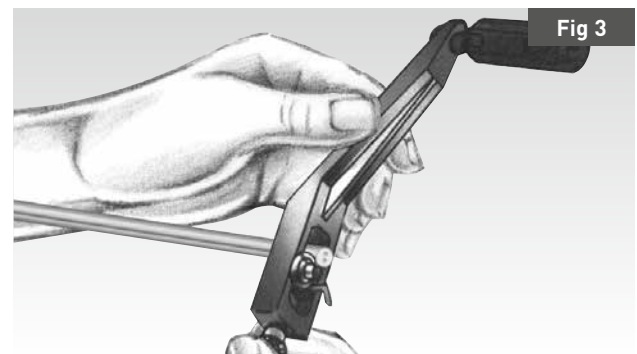

When using the Joistripper set the guide block as follows:

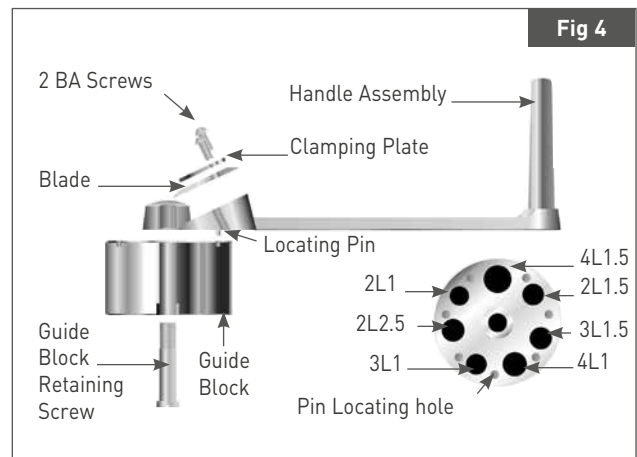

Unscrew the guide block retaining screw, recessed in the back of the guide block, in order to clear the block from the locating pin in the handle assembly. The block can then be rotated to fit the appropriate cable sizes and the locating pin engaged. Finger pressure only to be used. Do not force the guide block by tightening the retaining screw. Ensure no dirt is blocking the locating hole. Then tighten the retaining screw and the tool is ready for use. Do not adjust the blade. Refer to leaflet packed with tool before changing the blade.

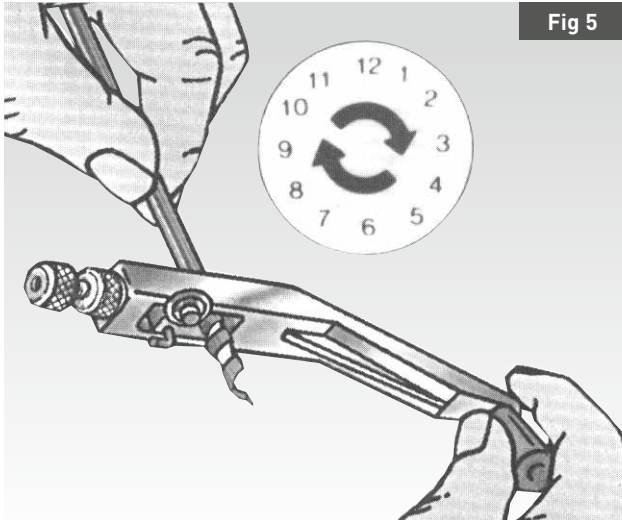

Rotate tool in a clockwise direction applying slight pressure in the direction of stripping until in the case of the ZSU and ZSUS Strippers sufficient swarf has been formed to allow it to be bent round the adjacent post (Fig. 5 and 6). This will prevent the tool snagging the swarf. Once stripping has commenced, all 3 rotary stripping tools will propel themselves along the cable.

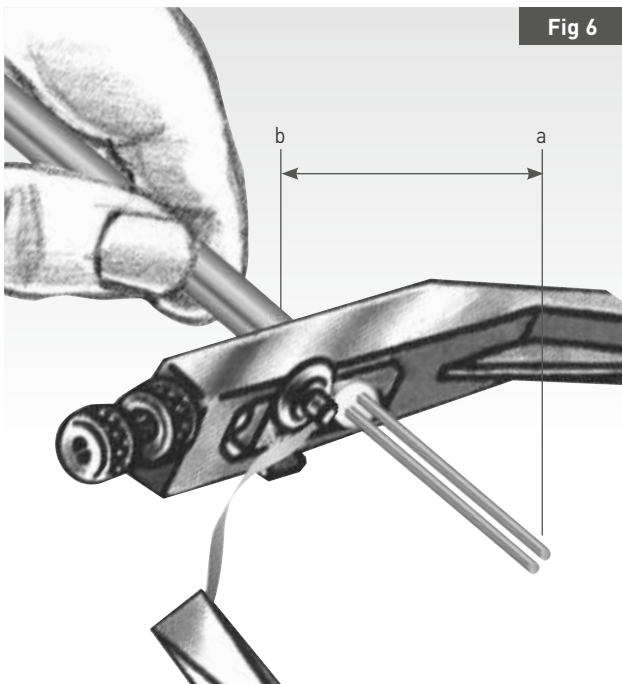

When sufficient sheath has been stripped the operation is terminated by gripping the cable with pliers at the point marked 'b' and allowing the tool to rotate against the jaws (Fig. 7). Remove the tool.

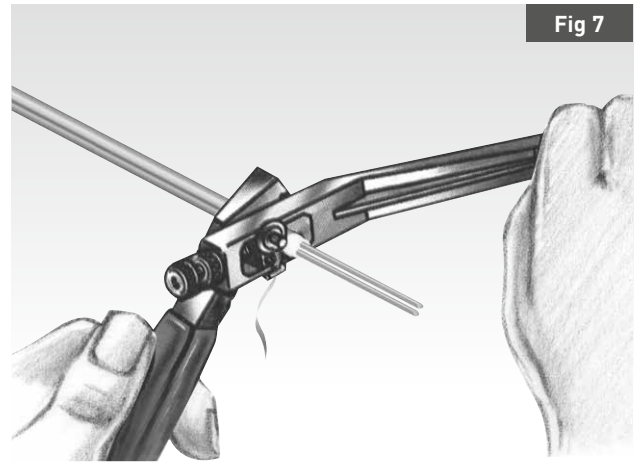

If the insulant has adhered to the conductors this should be removed. The cable is now ready for sealing.

Note:

- A) The Strippers will not operate satisfactorily if the cable sheath is flattened or distorted.**
- B) Large Stripper is illustrated here, the operations are similar for Small Stripper and Joistripper.**
- C) Spare blades for these tools are available from your local Pyrotenax stockists.**

Method 2 - Using Side Cutters

This method has the merit of employing a tool normally carried in any electrician's kit. Grip the edge of the sheath between the jaws and twist the wrist clockwise, then take a new grip and rotate through a small angle. (Fig 8).

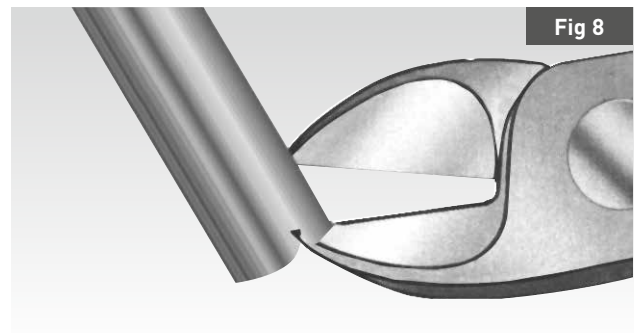

Continue this motion in a series of short 'rips' keeping the side-cutter at about 45° to the line of the cable, removing sheath spirally (Fig. 9).

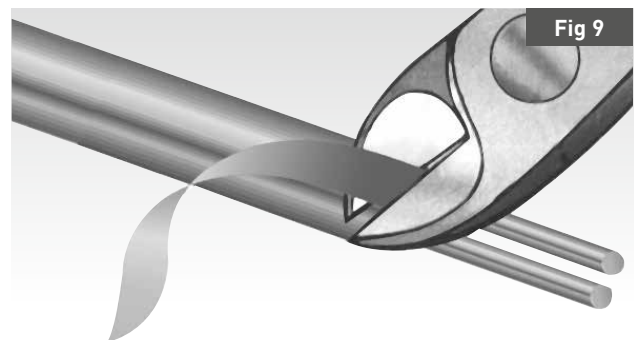

When approaching the terminating position the cable sheath should be ringed with a ringing tool. This tool, which is shown in use here (Fig 10), is used to cut a groove round the sheath so that it will break away cleanly and at exactly the right place. Tighten the wing nut until the wheels have enough grip to allow the tool to support its own weight in a horizontal position, then give an additional quarter to half a turn according to the size of the cable.

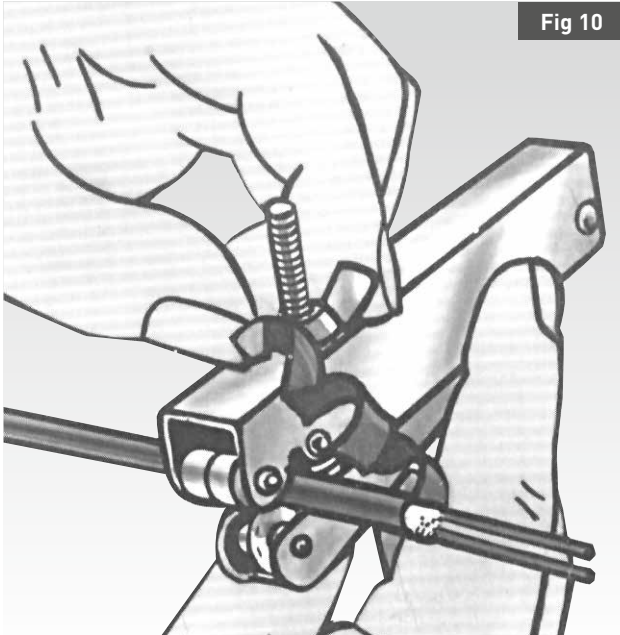

Fig 10

Rotate the cutter around the cable for one complete turn, or more if the first cut appears shallow. The correct depth for the groove is half the thickness of the sheath and reference to Fig. 11 will show the results of over or under cutting.

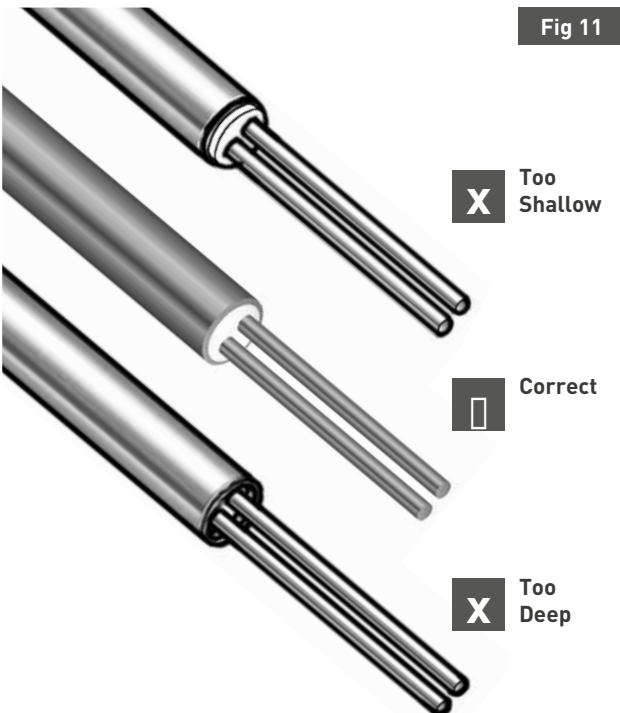

Fig 11

When the rip is about to break into the ring, bring side-cutters to right angles with the cable. Finish off with the point of side-cutters held parallel to the cable (Fig. 12).

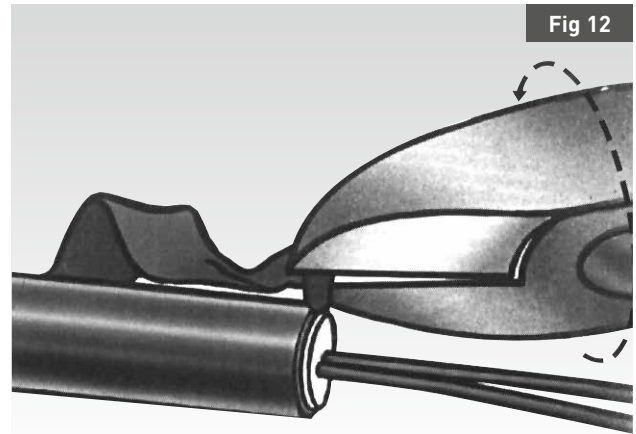

Fig 12

If the insulant has adhered to the conductors this should be removed. The cable is now ready for sealing.

Method 3 - Using the Fork Ended Stripping Rod

This is quicker than the previous method and especially useful on long tails. Such a tool can easily be made on site from a suitable piece of rod, the end being slotted with a hacksaw. Start the 'rip' with side-cutters, as previous method 2. Pick up the tag in the slot of the rod and twist it round the cable. Retain a 45° angle to the line of the cable allowing the swarf to spiral along the stripping rod (Fig 13). Break into the ring and finish with side-cutters as with method 2.

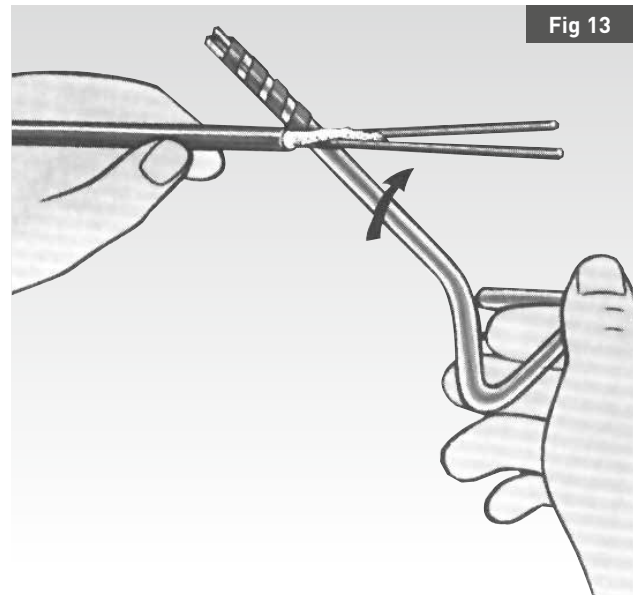

Fig 13

As the insulant has adhered to the conductors this should be removed. The cable is now ready for sealing.

Glands and Shrouds

Glands and if required gland shrouds, should be slid onto the cable sheath before screwing on the pot, unless using the Pyro Potter method (described later), when the gland is fitted at the same time as the pot.

Fitting the Screw-on-Pot

If there is any roughness left around the end of the cable sheath from the stripping operation, remove it by lightly running pliers or pipe-grips around the end of the sheath.

Three methods are available for fitting the pot.

- A) Using the Pyro Wench (20mm size seals only).
- B) Using the pliers or pipe grips.
- C) Using the Pyro Potter (Only possible when terminating with an RGM gland).

Using the Pyro Wench

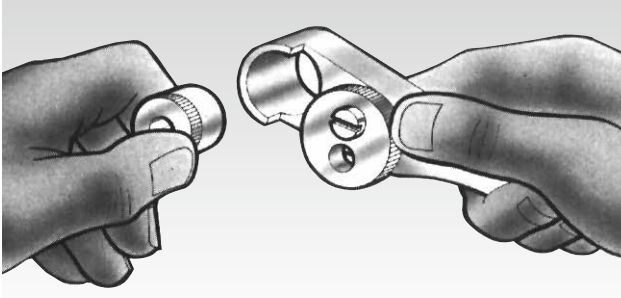

Insert the seal pot open end first into the tool recess.

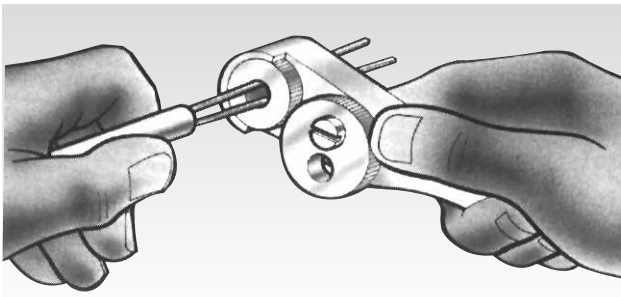

Feed the exposed conductors through the seal pot until the cable sheath is in contact with the self cutting thread of the pot.

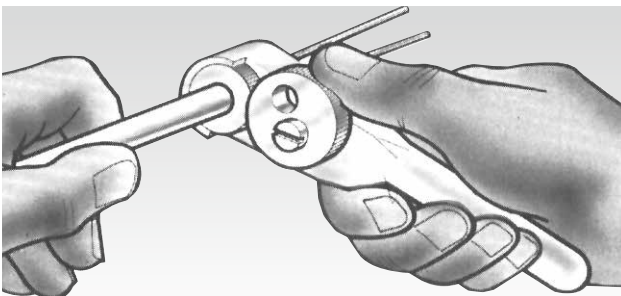

Engage the ratchet wheel into the knurled section of the pot and maintain this contact with thumb or finger as appropriate. Applying forward pressure and a cranking action, screw the pot squarely onto the cable.

The screwing action should continue until the sheath is level with or protruding slightly from the shoulder inside the pot (Fig 14a). In the case of the high temperature glazed insulator the pot should be screwed on until 1 to 2mm of sheath protrudes from the pot shoulder. With small diameter cable it is advisable to grip the cable sheath with pliers just behind the pot, to prevent twisting of the cable.

For earth tail seals the final stop position should be when the earth tail is midway between two adjacent conductors to ensure alignment with the pot closure (Fig 14b). The fitting operation may be assisted by applying a slight smear of oil to the sheath.

Using the Pliers or Pipe Grips

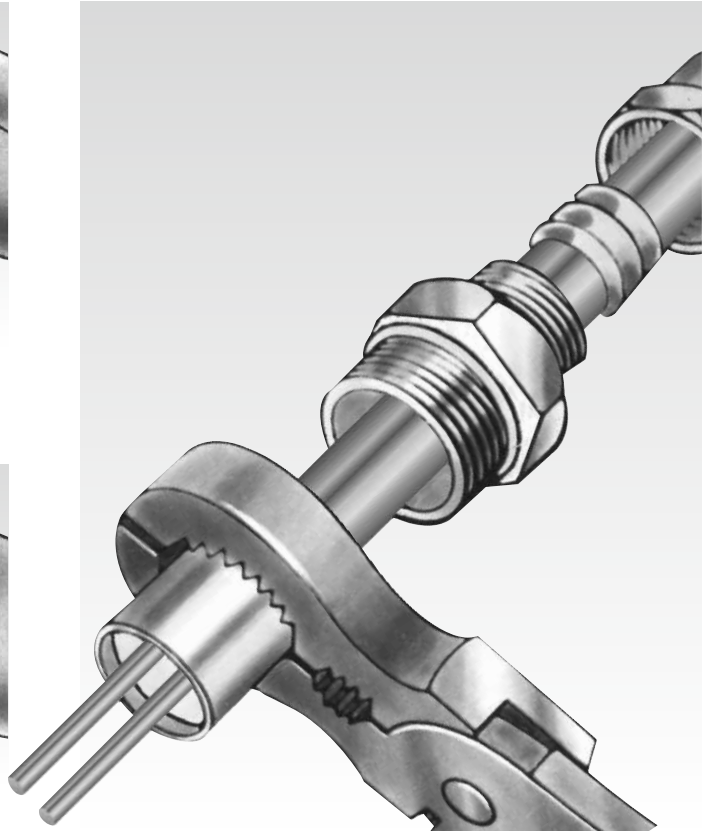

The pot which has a self cutting thread should be started by hand, place the parallel entry section of the pot over the end of the cable sheath, push and turn the pot squarely onto the cable using a clockwise rotation. Then grip the knurled base of the pot with the pliers and screw the pot onto the sheath until the sheath is level with or protruding slightly from the shoulder inside the pot (Fig 14a). In the case of the high temperature glazed insulator, it is necessary to screw the pot onto the sheath until 1 to 2mm of cable protrudes beyond the shoulder inside the pot.

With small diameter cable it is advisable to grip the cable sheath with pliers just behind the pot, to prevent twisting of the cable. Do not reverse the screwing motion whilst fitting the pot as this can cause slackness of the pot, which can affect sealing performance or earth continuity. When fitting an earth tail pot, the pot should be turned until the earth tail is midway between two adjacent conductors to ensure alignment with the pot closure (Fig 14b). The fitting operation may be assisted by applying a slight smear of oil to the sheath.

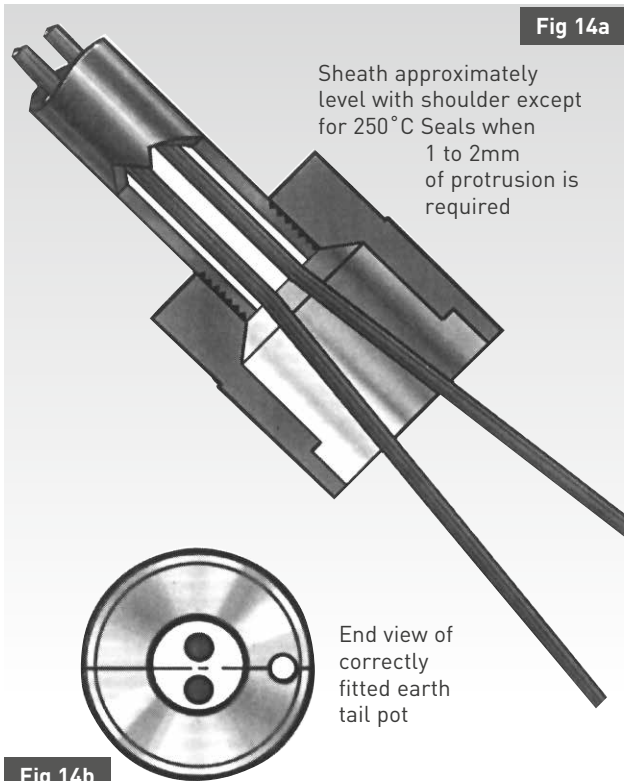

Fig 14b

Using the Pyro Potter

Pyro Potter tools are available for all sizes of pot. Place gland nut and compression ring on stripped end of cable and position the pot into gland body and screw into tool (Fig. 15). Finger tightness is not sufficient. The assembly must be lightly nipped up using pliers or a spanner.

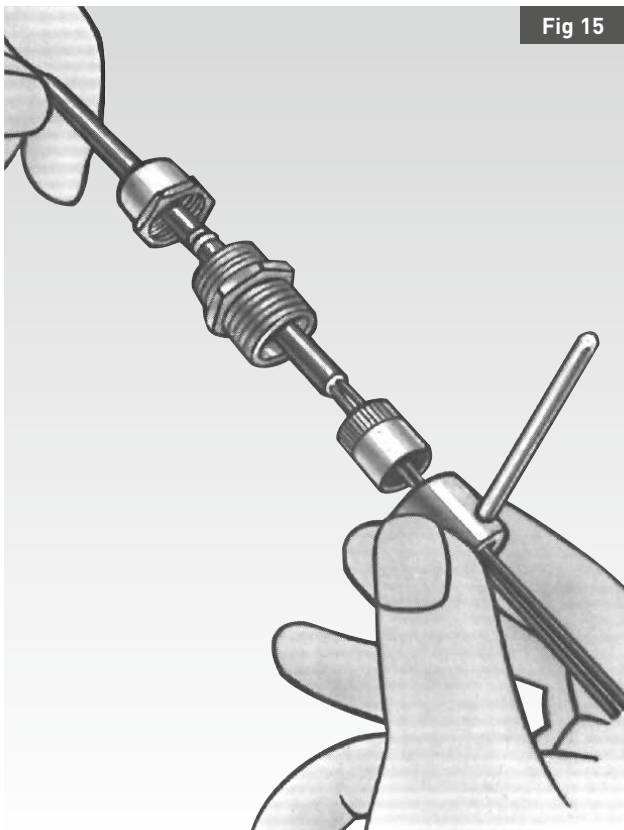

Fig 15

Turn Pyro Potter in a clockwise direction while applying sufficient forward pressure to engage internal screwthread (Fig. 16).

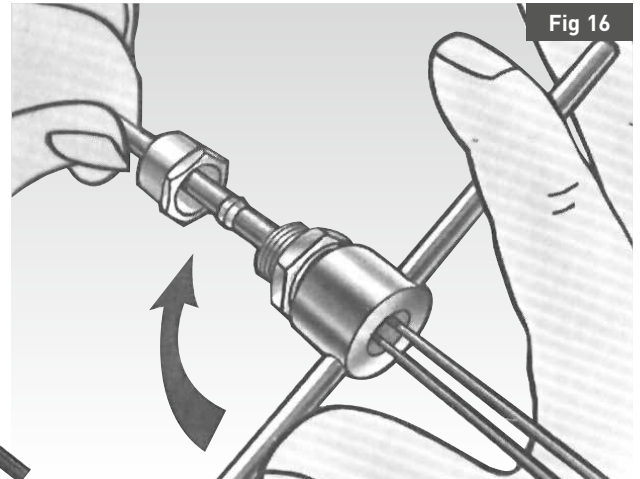
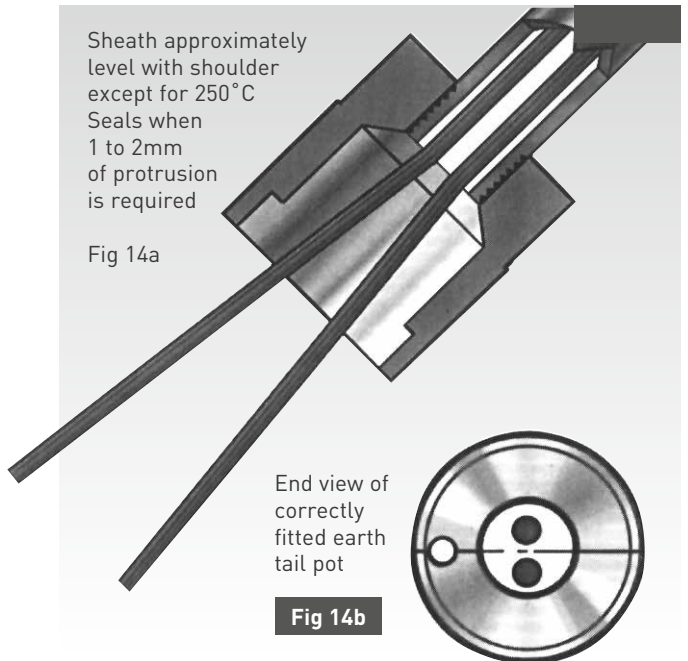

Fig 16

Continue rotating the tool until the sheath is level with or protruding slightly from the shoulder inside the pot (Fig. 14a). In the case of the high temperature glazed insulator, it is necessary to screw the pot onto the sheath until 1 to 2mm of cable protrudes beyond the shoulder inside the pot. With small diameter cables it is advisable to grip the cable sheath with pliers just behind the pot to prevent twisting of the cable.

Do not reverse the screwing motion whilst fitting the pot, as this can cause slackness of the pot which can affect sealing performance or earth continuity. When fitting an earth tail pot, the pot should be turned until the earth tail is midway between two adjacent conductors, to ensure alignment with the pot closure (Fig. 14b). The fitting operation may be assisted by applying a light smear of oil to the sheath.



Sheath approximately level with shoulder except for 250°C Seals when 1 to 2mm of protrusion is required

Fig 14a

End view of correctly fitted earth tail pot

Fig 14b

Remove the Pyro Potter from gland body (Fig 17). When unscrewing the Pyro Potter grip the gland body with pliers or a spanner to prevent the pot unscrewing from the sheath.

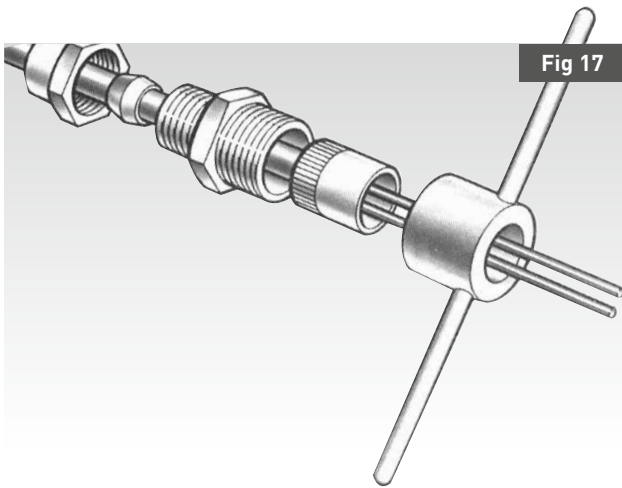

Fig 17

Filling the Pot

(105°C and Radiation Resistant Seals only). After fitting the brass pot, check for squareness by sliding the gland over the pot, remove any loose powder etc. that may have resulted from the screwing action.

For One, Two, Three, Four and Seven conductor cables:

When using the disc/sleeve assemblies, fit the headed sleeves into the disc as shown (Fig. 18). Pull head hard against face of disc.

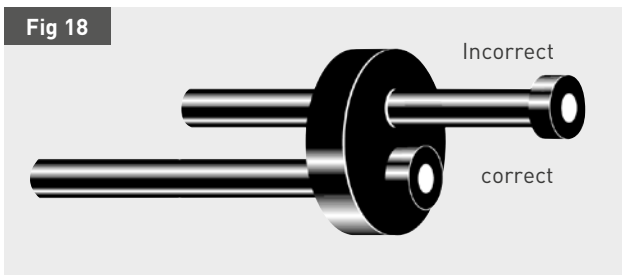

Fig 18

Slide the stub cap or disc/sleeve assembly over the conductors and into the pot recess to check for fit, then partially withdraw. In the case of Seven conductor cables this operation can be facilitated by shortening the outer ring of conductors by 10mm. When terminating multicore cables with 10mm², 16mm² or 25mm² conductors, the conductors should be 'set' within the pot to facilitate the location of the stub cap/disc sleeve assembly within the recess. Press the compound into the pot from one side only, to avoid cavities, with thumb preferably behind the paper to ensure cleanliness (Fig. 19). Fill the pot completely, overfilling slightly. Care should be taken to avoid contamination of the sealing compound.

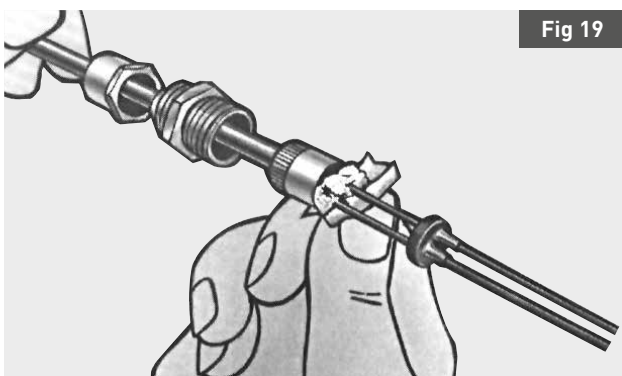

Fig 19

Slide the stub cap or disc/sleeve assembly up to the pot and press it into the pot recess with the aid of a pair of pliers, applying pressure only to the face of the cap or disc (Fig 20).

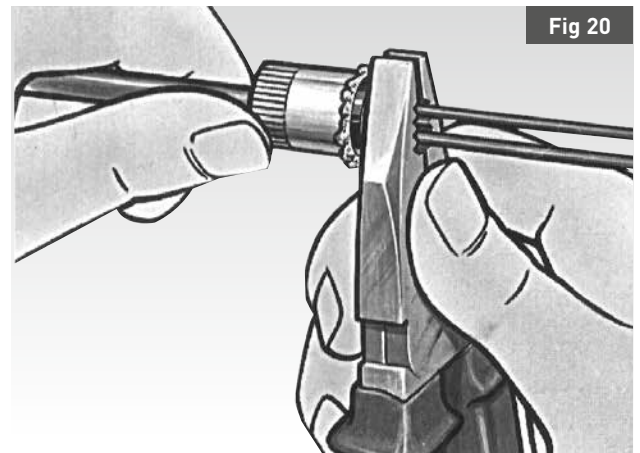

Fig 20

The seal is now ready for crimping.

For Twelve and Nineteen Conductor Cables:

The conductor length should be staggered as follows:

Twelve - Shorten the nine outer conductors Conductors by 10mm.

Nineteen - Shorten the twelve outer conductors Conductors by 20mm and the inner six conductors by 10mm (Fig. 21).

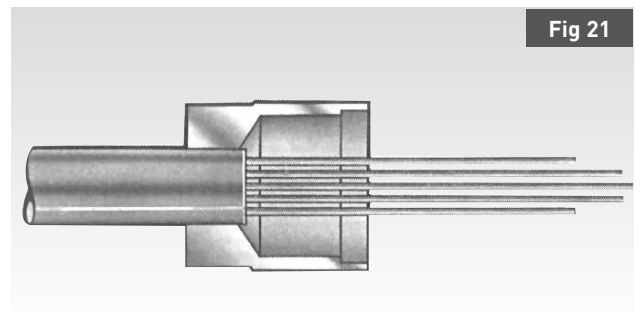

Fig 21

Spread out the outer conductors and push the compound around the inner conductor(s), with thumb behind the paper to ensure cleanliness. At the same time covering the cable face at the base of the pot (Fig. 22).

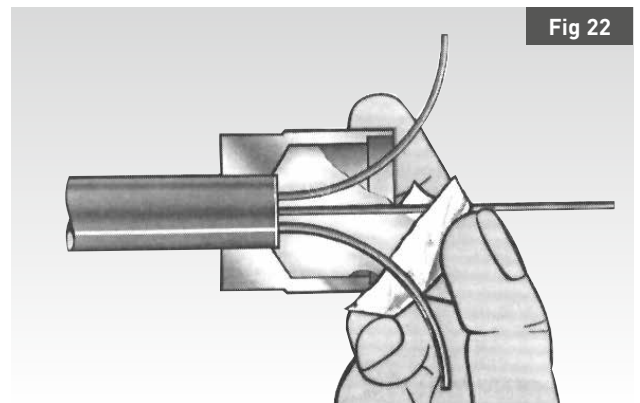

Fig 22

Pull the inner conductor(s) straight using pliers. Reposition the next layer of conductors and apply more compound as necessary before restraightening the conductors by gently pulling with pliers. In the case of Nineteen conductor cables repeat the above repositioning, filling and restraightening operations for the outermost layer of conductors. Fill the pot completely, from one side only, to avoid cavities, overfilling slightly. Care should be taken to avoid contamination of the sealing compound. Enter the conductors into the stub cap one at a time, starting with the inner conductors and taking care to avoid incorrect alignment. When all the conductors have been entered, push the stub cap into the pot recess with the aid of pliers, applying pressure only to the face of the cap (Fig. 20).

Crimping the Pot Closure

Two types of crimping tools are available.

A) The plate type 3 point Pyro-X-Crimp Ref. ZDD.

B) The Pyro Crimp Ref. ZDC20 and ZDC25.

Pyro-X-Crimp.

The plate type 3 point Pyro-X-Crimp Ref. ZDD (followed by pot size 20, 25, 32, or 40) is a low cost simple tool with a life of approximately 100 seals.

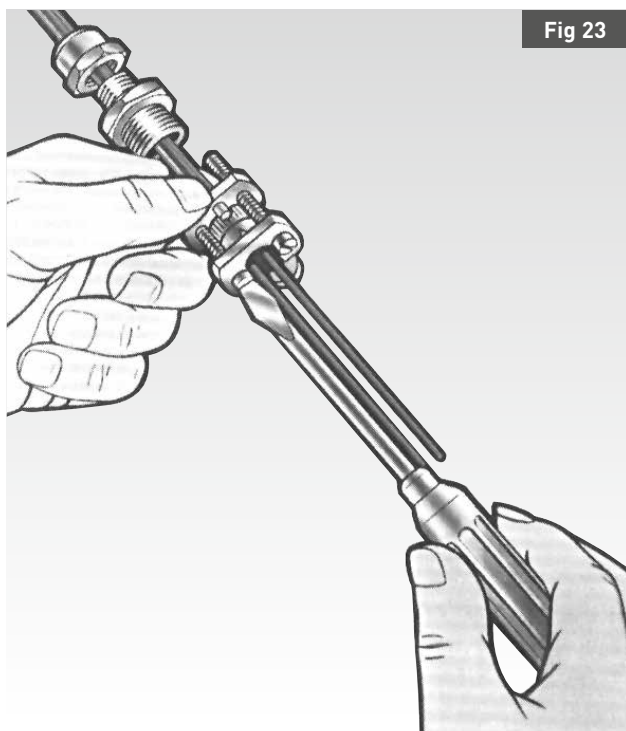

Fig 23

Fully slacken the two screws, slide the crimping plate over the conductors and up to the pot. Swivel the slotted base plate up around the cable behind the pot and tighten the two screws, which will drive the stub cap or disc fully into the pot recess and secure it in position by means of three indent crimps. Slacken the crews and remove the tool (Fig. 23).

The Pyro Crimp

The Pyro Crimp Ref. ZDC20 and ZDC25 provide three point crimps for 20 and 25mm size Screw on Seals. This tool has a longer life than the ZDD plate type tool. It is not available in either 32 or 40mm sizes.

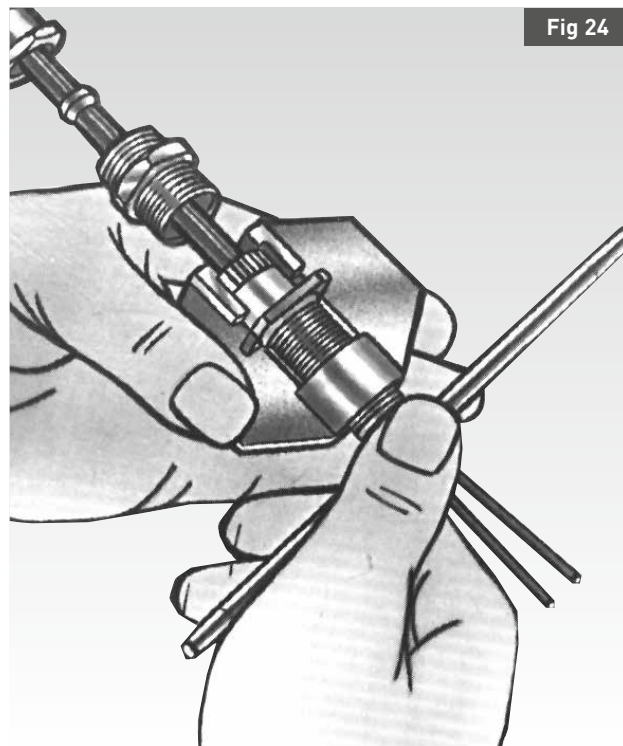

Fig 24

Fully slacken the drive screw by means of the handle. Slide the conductors through the hole in the crimping plate and through the centre of the hollow drive screw. Place the pot into the seating in the brass body and tighten the screw until it is fully hand tight, which will drive the stub cap or disc fully into the pot recess and secure it in position by means of three indent crimps. Then slacken and remove the tool (fig 24), taking care not to unscrew the pot. When using stub caps cut the conductor insulating sleeving to the required length and slide it over the conductors and onto the stubs.

The seal is now complete.

Cable with Outer Covering

When terminating cable provided with an outer covering for corrosion protection, any exposed cable sheath and brass gland must be covered with adhesive insulation tape after installation and prior to positioning the gland shroud.

Testing

Cables should only be tested after both ends have been terminated with a permanent seal. In order to prove the integrity of the seals the cable should be subject to a further insulation resistance test 24 hours later, when the insulation resistance should be at least 100MΩ.

The test voltage should be selected in accordance with BS 7671 IEE Regulations for Electrical Installation.

Never test a cable which has unsealed ends, because this will result in false readings.

Fig 25

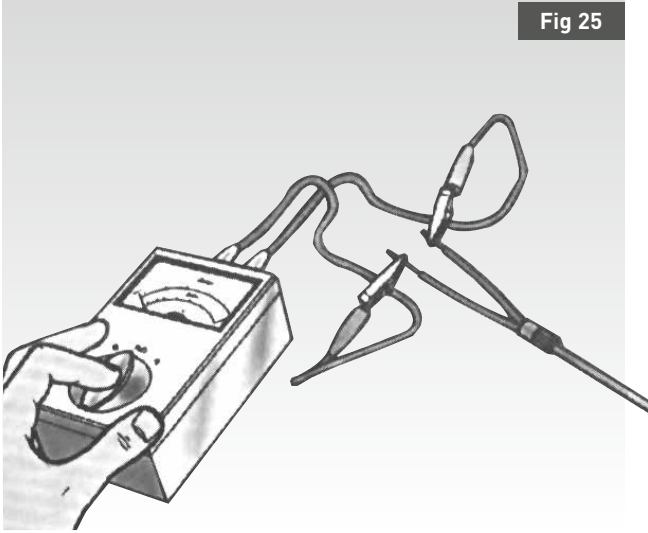

Identification

The conductors should be identified using a bell set, ohmmeter or similar instrument and then coded in accordance with the current requirements of BS 7671 IEE Regulations for Electrical Installations.

Fault Finding

If a cable exhibits a low insulation resistance and a faulty seal is suspected, the following simple test is very useful. When attempting to locate faults on circuits involving multiple cable runs, it is preferable to isolate and test individual cables so as to avoid the errors introduced by parallel connections.

Test to Verify Ingress of Moistur

Connect an insulation tester or ohmmeter between one conductor and the copper sheath, or between two conductors and obtain a steady reading (a hand powered insulation tester may not give a steady reading), apply a **slight** amount of heat to the cable sheath just behind the seal (a lighted match or cigarette lighter will give sufficient heat). If the seal is faulty and has allowed moisture to enter the cable, the meter reading will fall rapidly as soon as the heat is applied and start to recover when the heat is removed. In situations where it is not practicable to apply heat a freeze spray can be utilised, in which case the opposite effect is observed, ie. the meter reading will increase as the spray is applied and will fall as the cable returns to its original temperature. This technique is also suitable for locating moisture in the cable at positions away from the seals, as can occur with severe sheath damage. Further advice on all aspects of fault finding may be obtained by contacting our Washington Factory.

Removal of a Faulty Seal

Open up the crimps with a pointed tool, e.g. a small screwdriver or side-cutters, to free the pot closure so that it and the sleeving can be removed from the conductors. Scrape out the compound and unscrew the pot from the cable sheath with a pair of pliers or pipe grips. Discard the compound and pot. Remove all the remaining compound from the conductors and cable end and ensure that no metallic or other foreign bodies remain to contaminate the cable insulant. If possible remove the threaded length of the cable sheath using one of the sheath stripping methods described previously.

Improving the Insulation Resistance

As the mineral insulant is capable of absorbing moisture, it is not usually necessary to 'dry cable out' before reterminating. When a faulty seal has been removed, all that is necessary is to replace it with an effective seal and the insulation resistance will begin to recover. The rate of improvement will depend upon the quantity of moisture which has entered the cable.

Only when the insulation resistance is very low or if an immediate improvement is required, will it be necessary to dry out the cable end prior to reterminating. When drying out, first use the technique described previously for locating moisture to ascertain how far moisture has penetrated along the cable. Then heat the cable to observe significant discolouration at a point approximately 100mm into the cable from the limit of the moisture ingress, slowly move the heated zone towards the end of the cables so that any moisture will be driven out.

It may be necessary to repeat this operation if the cable has absorbed a considerable amount of moisture over several years. It is essential that the heating is commenced further along the cable than the moisture has penetrated, otherwise the moisture may be driven further into the cable. With covered cable, it will be necessary to 'pare' the outer covering back clear of the section to be heated. The covering should be then folded and taped back to prevent damage whilst the cable is hot. After the cable has cooled the outer covering can be replaced and covered with a helical layer of adhesive insulation tape with a 50% overlap.

Replacing the Seal

The replacement seal should then be fitted and tested as described previously.

Pyro Mi Wiring Cables Installation Tools

ALTERNATIVE STRIPPING TOOLS



LARGE PYRO STRIPPER
Ref. ZSU
(Spare Blade Ref. ZSUB).

For stripping the sheath on all sizes of cable, except 1H300 and 1H400.



SMALL PYRO STRIPPER
Ref. ZSUS
(Spare Blade Ref. ZSUBS).

For stripping cables with diameters below 9mm.

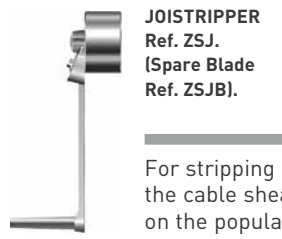

JOISTRIPPER
Ref. ZSJ.
(Spare Blade Ref. ZSJB).

For stripping the cable sheath on the popular light duty cable sizes 2L1, 2L1.5, 2L2.5, 3L1, 4L1 and 4L1.5.



PYRO RINGER
Ref. ZR.

This tool is used to arrest the removal of the sheath at a selected point, and is used in conjunction with sidecutters.

ALTERNATIVE POTTING AND CRIMPING TOOLS



PYRO WRENCH
Ref. ZRP.

An easy fit ratchet tool for screwing on 20mm brass seal pots.



PYRO POTTER
Ref. ZPM.
Followed by 20, 25, 32 or 40.

Used in connection with appropriate cable gland to screw on the brass pot. Four sizes are available to cover 20, 25, 32 & 40mm seals.



PYRO CRIMP
Ref. ZDC.
Followed by 20 or 25.

A quick method of crimping the mouth of the pot to secure the closure. Two sizes are available to cover 20 and 25mm seal sizes.

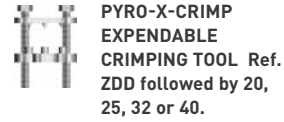

PYRO-X-CRIMP EXPENDABLE CRIMPING TOOL Ref. ZDD followed by 20, 25, 32 or 40.

For crimping the mouth of the pot to secure the closure. It is used in conjunction with a screwdriver. Four sizes are available to cover 20, 25, 32 and 40mm seal sizes.

INSTALLATION TOOLS



PYRO BENDER
Ref. ZBLA for cables between 10 and 16mm.
ZBLB for cables between 16 and 27mm diameter.

The majority of cables can be easily bent by hand. However, two tools are available to produce neat, reproducible bends.



PYRO STRAIGHTENER
Ref. ZBS for cables up to 12mm.

To assist in the preliminary straightening of cables prior to fixing. For larger cables initial dressing can be carried out with the aid of a Pyro Bender.

This document was supplied to you by:

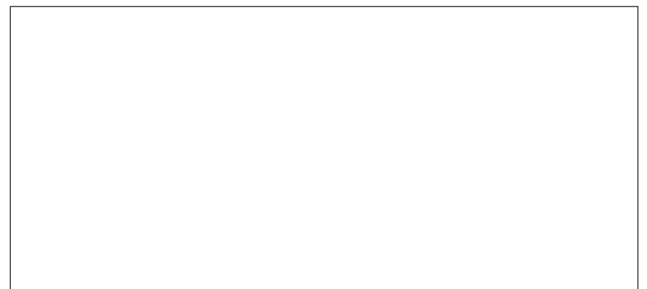

WWW.PENTAIRTHERMAL.COM

UNITED KINGDOM

Tel. 0800 969013

Fax 0800 968624

salesthermaluk@pentair.com

All Pentair trademarks and logos are owned by Pentair or its global affiliates. Pentair reserves the right to change specifications without prior notice.

© 2015 Pentair.

 @pentairTBS